

## 製品仕様書

製品名称 : システムネダN型

### 目次

1. 製品仕様
2. 製品形状図
3. 適応床高
4. 梱包仕様

泰成 株式会社

〒399-4102 長野県駒ヶ根市飯坂2-8-34

## 1. 製品仕様

### 1-1. システムネダ

#### ① 支持ネダ

項目	仕様・品質
ネダ部材質	単板積層材または普通合板 F☆☆☆☆
ナット部材質	JIS G 3507-1 (冷間圧造用炭素鋼-第1部:線材) SWRCH10R (相当) または JIS G 3507-2 (冷間圧造用炭素鋼-第2部:線) SWCH10R (相当) または JIS G 3505 (軟鋼線材) SWRM6 (相当) または SWRCH10R (相当)
ナット部表面処理	JIS H 8610 (電気亜鉛めっき) 3級
寸法	2. 製品形状図参照
外観	ネジ部にキズのないこと
	めっき剥離のないこと
その他	使用上支障のないこと

#### ② 支持ボルト

項目	仕様・品質
ボルト部材質	JIS G 3445 (機械構造用炭素鋼鋼管) STKM11A (相当) または STKM12C (相当) または 溶融めっき鋼帯 (ZAM) STKM11A (相当)
ボルト部表面処理*	JIS H 8610 (電気亜鉛めっき) 3級
防振ゴム部材質	JIS K 6386 (防振ゴム・ゴム材料の区分) A種 硬さ 83±5°
寸法	2. 製品形状図参照
外観	ネジ部にキズのないこと
	めっき剥離のないこと
その他	使用上支障のないこと

※溶融めっき鋼帯は表面処理済。

### 1-2.Sパッキン

項目	仕様・品質
材質	ポリエチレン発泡体
寸法	(幅)15×(長)40×(厚)15mm
その他	使用上支障のないこと

### 1-3.接着剤

項目	仕様・品質
材質	ポリウレタン系
寸法	400ml または 200ml
その他	シアン化合物、有機リン化合物、ヒ素及びその化合物、ホルムアルデヒド、水質汚濁防止法に係る重金属類、PCB、フェノール等の物質、トルエン、キシレン及び木材保存剤、可塑剤、防蟻剤は使用していない。

ST-GJ-209(第2版)2023.02.10

## 2. 製品形状図

### 2-1. システムネダ

#### 2-1-1. N2型

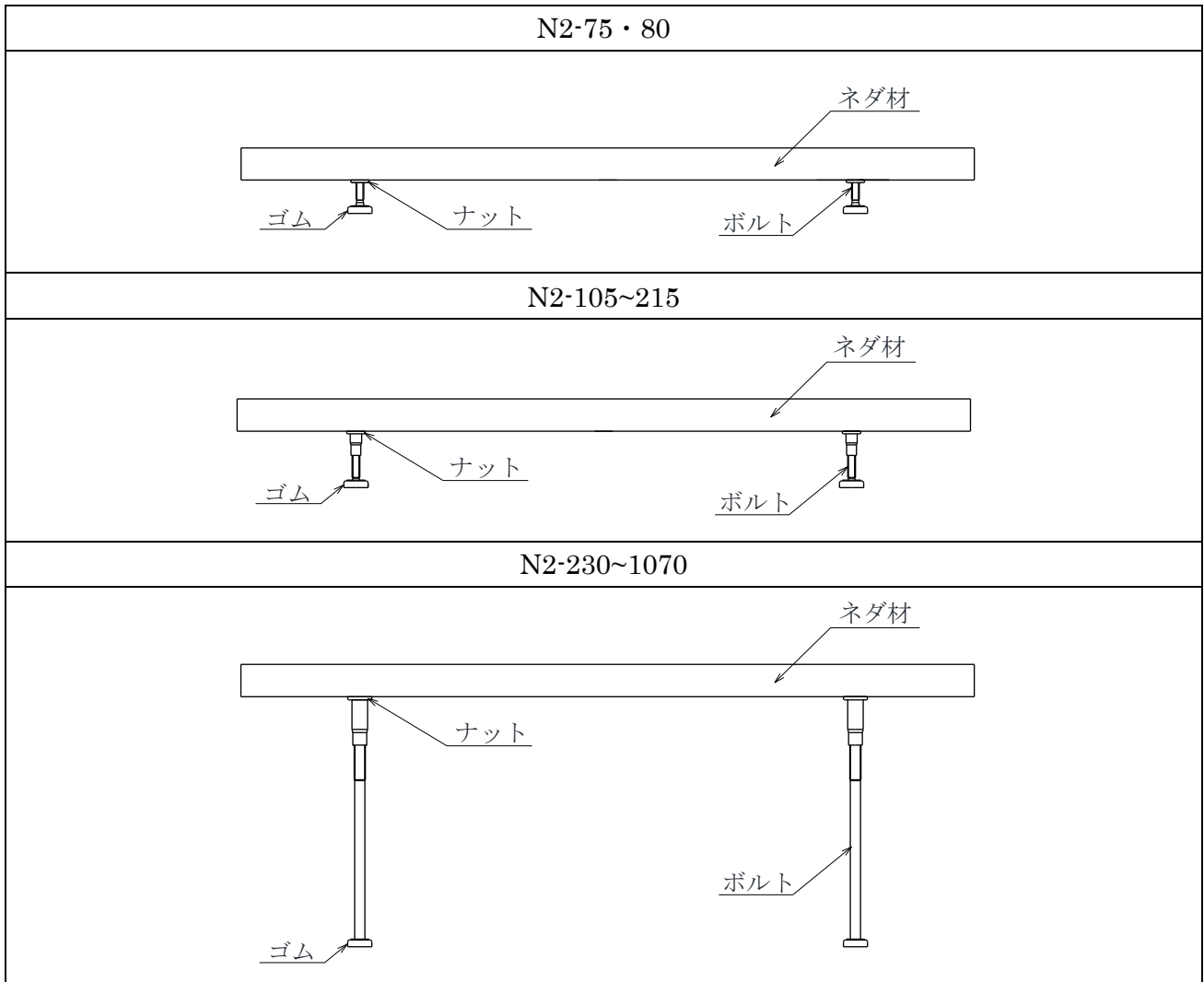

2-1-2.N3型

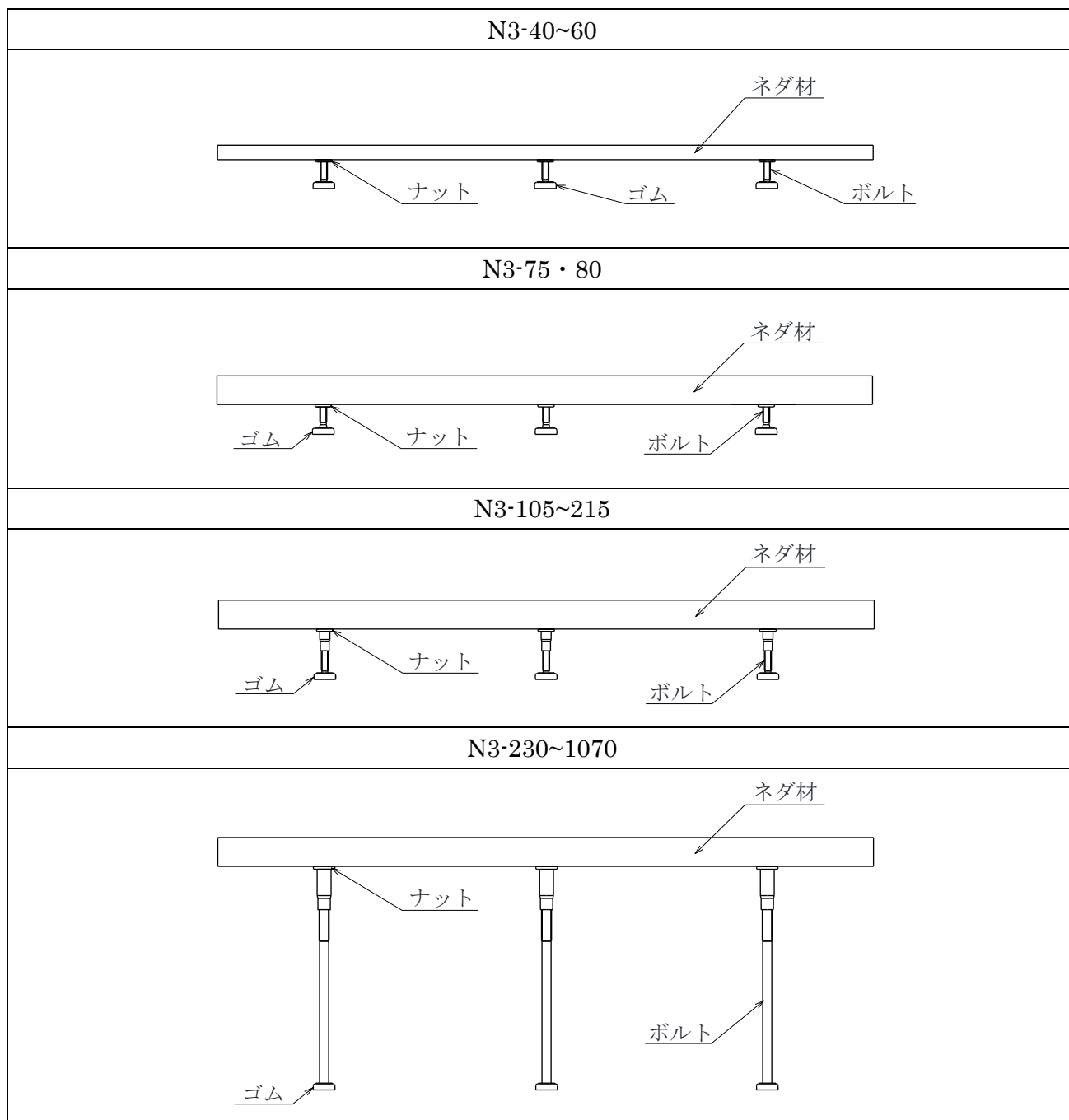

## 2-2.ネダ材

### 2-2-1.N2型

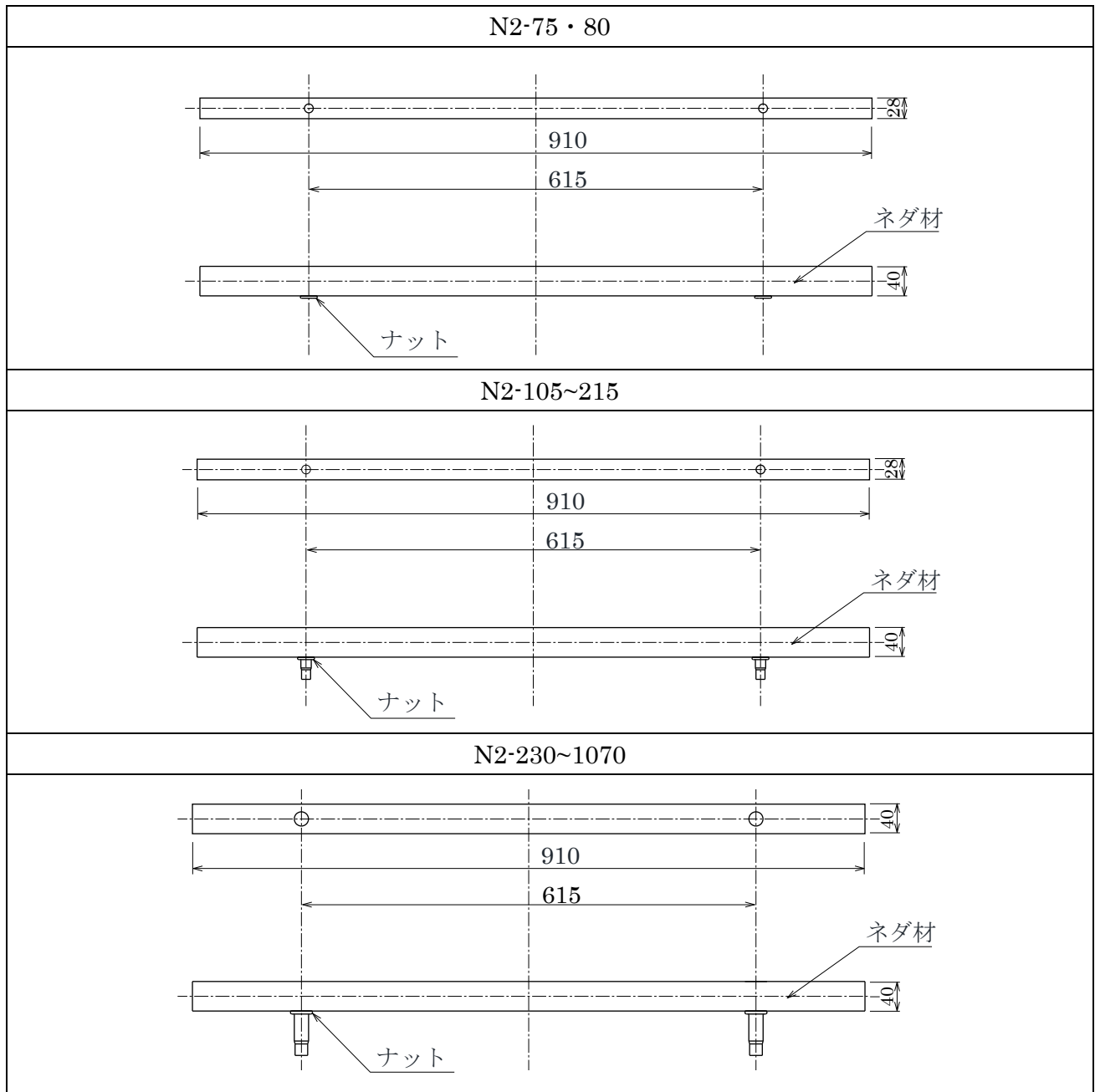

2-2-2.N3型

N3-40~60

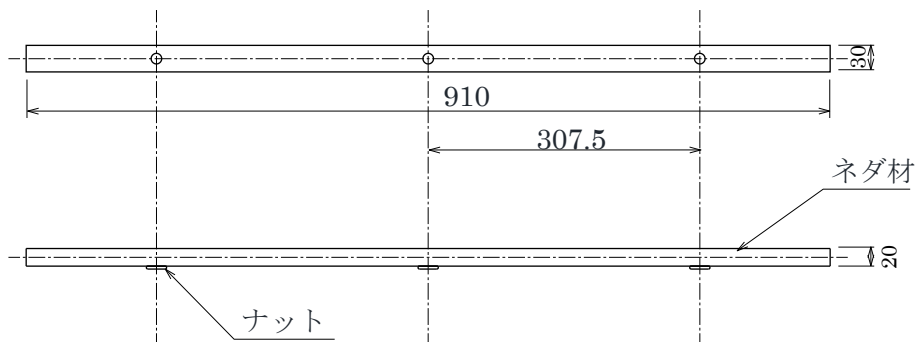

N3-75・80

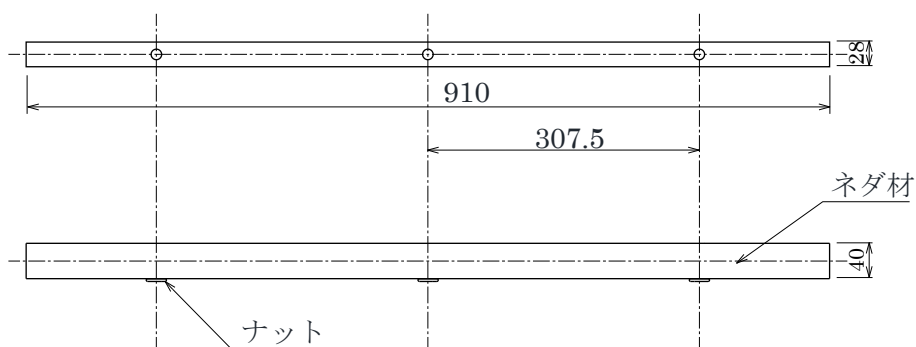

N3-105~215

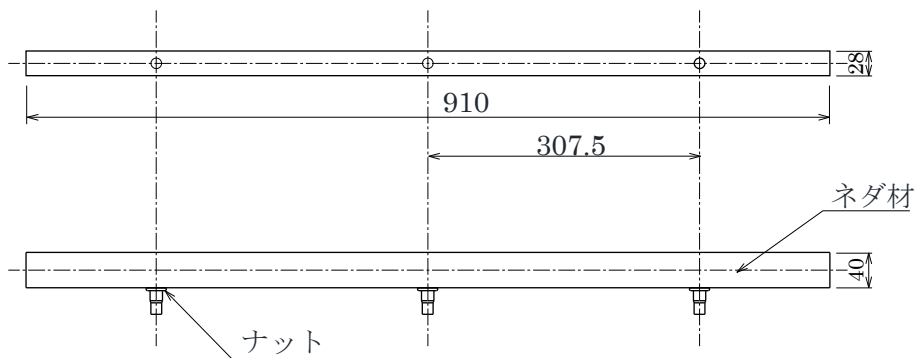

N3-230~1070

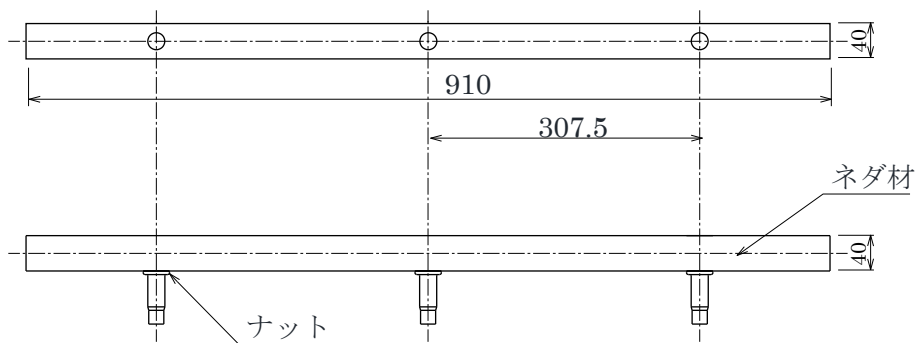

## 2-3.支持ボルト

### 2-3-1.N2型

N2-75~215		N2-230~1070																																																									
<p>ボルト(W3/8)</p> <p>A以上(有効ねじ)</p> <p>L(ボルト長さ)</p> <p>9.4</p> <p>φ30</p> <p>ゴム</p>	<table border="1"> <thead> <tr> <th>品番</th> <th>L</th> <th>A</th> </tr> </thead> <tbody> <tr> <td>N2-75</td> <td>50</td> <td>38.5</td> </tr> <tr> <td>N2-80</td> <td>60</td> <td>48.5</td> </tr> <tr> <td>N2-105</td> <td>60</td> <td>48.5</td> </tr> <tr> <td>N2-125</td> <td>90</td> <td>78.5</td> </tr> <tr> <td>N2-155</td> <td>120</td> <td>87.0</td> </tr> <tr> <td>N2-185</td> <td>150</td> <td>87.0</td> </tr> <tr> <td>N2-215</td> <td>180</td> <td>87.0</td> </tr> </tbody> </table>	品番	L	A	N2-75	50	38.5	N2-80	60	48.5	N2-105	60	48.5	N2-125	90	78.5	N2-155	120	87.0	N2-185	150	87.0	N2-215	180	87.0	<p>ボルト(M14)</p> <p>100以上(有効ねじ)</p> <p>L(ボルト長さ)</p> <p>9.9</p> <p>φ30</p> <p>ゴム</p>	<table border="1"> <thead> <tr> <th>品番</th> <th>L</th> </tr> </thead> <tbody> <tr> <td>N2-230</td> <td>185</td> </tr> <tr> <td>N2-290</td> <td>245</td> </tr> <tr> <td>N2-350</td> <td>305</td> </tr> <tr> <td>N2-410</td> <td>365</td> </tr> <tr> <td>N2-470</td> <td>425</td> </tr> <tr> <td>N2-530</td> <td>485</td> </tr> <tr> <td>N2-590</td> <td>545</td> </tr> <tr> <td>N2-650</td> <td>605</td> </tr> <tr> <td>N2-710</td> <td>665</td> </tr> <tr> <td>N2-770</td> <td>725</td> </tr> <tr> <td>N2-830</td> <td>785</td> </tr> <tr> <td>N2-890</td> <td>845</td> </tr> <tr> <td>N2-950</td> <td>905</td> </tr> <tr> <td>N2-1010</td> <td>965</td> </tr> <tr> <td>N2-1070</td> <td>1025</td> </tr> </tbody> </table>	品番	L	N2-230	185	N2-290	245	N2-350	305	N2-410	365	N2-470	425	N2-530	485	N2-590	545	N2-650	605	N2-710	665	N2-770	725	N2-830	785	N2-890	845	N2-950	905	N2-1010	965	N2-1070	1025
	品番	L	A																																																								
	N2-75	50	38.5																																																								
	N2-80	60	48.5																																																								
	N2-105	60	48.5																																																								
	N2-125	90	78.5																																																								
	N2-155	120	87.0																																																								
	N2-185	150	87.0																																																								
N2-215	180	87.0																																																									
品番	L																																																										
N2-230	185																																																										
N2-290	245																																																										
N2-350	305																																																										
N2-410	365																																																										
N2-470	425																																																										
N2-530	485																																																										
N2-590	545																																																										
N2-650	605																																																										
N2-710	665																																																										
N2-770	725																																																										
N2-830	785																																																										
N2-890	845																																																										
N2-950	905																																																										
N2-1010	965																																																										
N2-1070	1025																																																										

### 2-3-2.N3型

N3-40~215		N3-230~1070																																																																		
<p>ボルト(W3/8)</p> <p>A以上(有効ねじ)</p> <p>L(ボルト長さ)</p> <p>9.4</p> <p>φ30</p> <p>ゴム</p>	<table border="1"> <thead> <tr> <th>品番</th> <th>L</th> <th>A</th> </tr> </thead> <tbody> <tr> <td>N3-40</td> <td>30</td> <td>18.5</td> </tr> <tr> <td>N3-50</td> <td>40</td> <td>28.5</td> </tr> <tr> <td>N3-60</td> <td>50</td> <td>38.5</td> </tr> <tr> <td>N3-75</td> <td>50</td> <td>38.5</td> </tr> <tr> <td>N3-80</td> <td>60</td> <td>48.5</td> </tr> <tr> <td>N3-105</td> <td>60</td> <td>48.5</td> </tr> <tr> <td>N3-125</td> <td>90</td> <td>78.5</td> </tr> <tr> <td>N3-155</td> <td>120</td> <td>87.0</td> </tr> <tr> <td>N3-185</td> <td>150</td> <td>87.0</td> </tr> <tr> <td>N3-215</td> <td>180</td> <td>87.0</td> </tr> </tbody> </table>	品番	L	A	N3-40	30	18.5	N3-50	40	28.5	N3-60	50	38.5	N3-75	50	38.5	N3-80	60	48.5	N3-105	60	48.5	N3-125	90	78.5	N3-155	120	87.0	N3-185	150	87.0	N3-215	180	87.0	<p>ボルト(M14)</p> <p>100以上(有効ねじ)</p> <p>L(ボルト長さ)</p> <p>9.9</p> <p>φ30</p> <p>ゴム</p>	<table border="1"> <thead> <tr> <th>品番</th> <th>L</th> </tr> </thead> <tbody> <tr> <td>N3-230</td> <td>185</td> </tr> <tr> <td>N3-290</td> <td>245</td> </tr> <tr> <td>N3-350</td> <td>305</td> </tr> <tr> <td>N3-410</td> <td>365</td> </tr> <tr> <td>N3-470</td> <td>425</td> </tr> <tr> <td>N3-530</td> <td>485</td> </tr> <tr> <td>N3-590</td> <td>545</td> </tr> <tr> <td>N3-650</td> <td>605</td> </tr> <tr> <td>N3-710</td> <td>665</td> </tr> <tr> <td>N3-770</td> <td>725</td> </tr> <tr> <td>N3-830</td> <td>785</td> </tr> <tr> <td>N3-890</td> <td>845</td> </tr> <tr> <td>N3-950</td> <td>905</td> </tr> <tr> <td>N3-1010</td> <td>965</td> </tr> <tr> <td>N3-1070</td> <td>1025</td> </tr> </tbody> </table>	品番	L	N3-230	185	N3-290	245	N3-350	305	N3-410	365	N3-470	425	N3-530	485	N3-590	545	N3-650	605	N3-710	665	N3-770	725	N3-830	785	N3-890	845	N3-950	905	N3-1010	965	N3-1070	1025
	品番	L	A																																																																	
	N3-40	30	18.5																																																																	
	N3-50	40	28.5																																																																	
	N3-60	50	38.5																																																																	
	N3-75	50	38.5																																																																	
	N3-80	60	48.5																																																																	
	N3-105	60	48.5																																																																	
	N3-125	90	78.5																																																																	
	N3-155	120	87.0																																																																	
N3-185	150	87.0																																																																		
N3-215	180	87.0																																																																		
品番	L																																																																			
N3-230	185																																																																			
N3-290	245																																																																			
N3-350	305																																																																			
N3-410	365																																																																			
N3-470	425																																																																			
N3-530	485																																																																			
N3-590	545																																																																			
N3-650	605																																																																			
N3-710	665																																																																			
N3-770	725																																																																			
N3-830	785																																																																			
N3-890	845																																																																			
N3-950	905																																																																			
N3-1010	965																																																																			
N3-1070	1025																																																																			

### 3. 適応床高（ネダ天端までの高さ）

N2型

品番	適応床高(mm)
N2- 75	58 ~ 90
N2- 80	65 ~ 100
N2- 105	86 ~ 127
N2- 125	95 ~ 157
N2- 155	125 ~ 187
N2- 185	155 ~ 217
N2- 215	185 ~ 247
N2- 230	191 ~ 275
N2- 290	251 ~ 335
N2- 350	311 ~ 395
N2- 410	371 ~ 455
N2- 470	431 ~ 515
N2- 530	491 ~ 575
N2- 590	551 ~ 635
N2- 650	611 ~ 695
N2- 710	671 ~ 755
N2- 770	731 ~ 815
N2- 830	791 ~ 875
N2- 890	851 ~ 935
N2- 950	911 ~ 995
N2-1010	971 ~ 1055
N2-1070	1031 ~ 1115

N3型

品番	適応床高(mm)
N3- 40	38 ~ 50
N3- 50	45 ~ 60
N3- 60	55 ~ 70
N3- 75	58 ~ 90
N3- 80	65 ~ 100
N3- 105	86 ~ 127
N3- 125	95 ~ 157
N3- 155	125 ~ 187
N3- 185	155 ~ 217
N3- 215	185 ~ 247
N3- 230	191 ~ 275
N3- 290	251 ~ 335
N3- 350	311 ~ 395
N3- 410	371 ~ 455
N3- 470	431 ~ 515
N3- 530	491 ~ 575
N3- 590	551 ~ 635
N3- 650	611 ~ 695
N3- 710	671 ~ 755
N3- 770	731 ~ 815
N3- 830	791 ~ 875
N3- 890	851 ~ 935
N3- 950	911 ~ 995
N3-1010	971 ~ 1055
N3-1070	1031 ~ 1115



## 4. 梱包仕様

### 4-1. 梱包外観

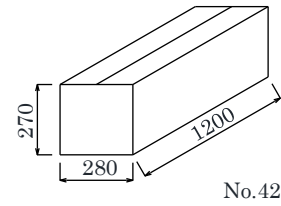
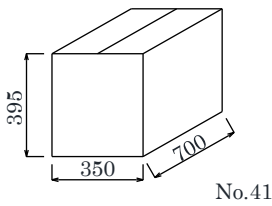
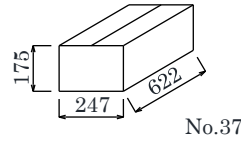
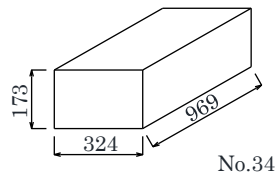
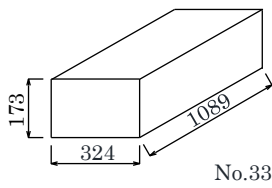

### 4-2. 梱包重量

品番	梱包重量(kg/箱)		入数		梱包箱 (mm)	上段ボルト
	ボルト	ネダ	ボルト	ネダ		下段ボルト
N2- 75	14.8		40	20	ビニル袋 No.33 1089×324×173	
N2- 80	14.9					
N2- 105	15.5					
N2- 125	15.9					
N2- 155	16.4					
N2- 185	17.0					
N2- 215	17.6					
N2- 230	4.4	18.8	28	14	No.37 622×247×175 No.34 969×324×173	
N2- 290	5.4					
N2- 350	6.4					
N2- 410	7.4					
N2- 470	8.4					
N2- 530	10.1					
N2- 590	11.1				No.41 700×350×395 No.34 969×324×173	
N2- 650	12.1					
N2- 710	13.2					
N2- 770	14.2					
N2- 830	15.2					No.42 1200×280×270 No.34 969×324×173
N2- 890	16.2					
N2- 950	17.2					
N2-1010	18.2					
N2-1070	19.2					

品番	梱包重量(kg/箱)		入数		梱包箱 (mm)	上段ボルト
	ボルト	ネダ	ボルト	ネダ		下段ボルト
N3- 40	16.1		90	30	ビニル袋 No.34 969×324×173	
N3- 50	16.4					
N3- 60	16.8					
N3- 75	15.7		60	20	ビニル袋 No.33 1089×324×173	
N3- 80	15.9					
N3- 105	16.8					
N3- 125	17.4					
N3- 155	18.2					
N3- 185	19.1					
N3- 215	20.0					
N3- 230	6.3	19.9	42	14	No.37 622×247×175 No.34 969×324×173	
N3- 290	7.8					
N3- 350	9.3					
N3- 410	10.8					
N3- 470	12.2					
N3- 530	14.5					
N3- 590	16.0					
N3- 650	17.4					
N3- 710	20.6*					
N3- 770	22.1*					
N3- 830	23.6*					
N3- 890	25.1*					
N3- 950	26.5*					
N3-1010	28.0*					
N3-1070	29.5*					
					No.41 700×350×395 No.34 969×324×173	
					No.42×2箱 1200×280×270 No.34 969×324×173	

注) ※印を付した重量は、ネダに対応させた2箱分の値で表記しています。

仕様は予告なく変更することがあります。